

# MLC150-1

## Product Guide

ASME B30.5  
Imperial



### Features

- 165 USt capacity
- 4701 ft-kips maximum load moment
- 256 ft No. 350 main boom
- 80 ft No. 134 fixed jib
- 170 ft No. 135 luffing jib
- 325 hp Tier 4 Final / Stage V engine

# MANITOWOC MLC150-1

The MLC150-1 provides a broad range of features that will undoubtedly be translated into jobsite benefits that increase productivity and save money.

## Features

### > Comfortable Cab Design

- 10% more legroom for operator
- Full high back seat with headrest and moveable riser supports operator comfortably
- Utilizes Crane Control System (CCS)
- Storage shelving located in the rear of the cab
- Redesigned consoles providing more legroom
- Left side console rotates for improved egress
- Six-way electric seat riser/slider
- Common with the MLC100-1



### > Efficient Self-Assembly

- Gantry raised counterweight reduces components and maintenance
- Boom butt mounted sheaves allow for reeving assembly hook without installing boom top
- Button style wire rope terminations for easy reeving
- Steel straps provide easy assembly and storage of boom suspension



## Job site benefits

### Transport and Assembly

- Designed to be transported with minimal permitted loads
- Adequate hook height allows for complete self-assembly with various trailer heights
- Steel straps reduce time and effort of assembly boom suspension

### Serviceability and support

- Elimination of wireless components to reduce complexity for increased reliability
- Cummins engine, cooler, air cleaner and after treatment package allows for better serviceability
- Crane Control System (CCS) allows for troubleshooting through the control system in the cab
- Codes can be cross referenced through the Manitowoc diagnostics code app
- Supported by Manitowoc's world class dealer network

## What you need, when you need it.

**Get right to work with the right equipment** — Manitowoc Finance gives you access to flexible, affordable financing you can use to seize profitable new opportunities as they arise.

**Feel confident in your investment** — rest easy with the assurance of the world's most advanced crane service and support network.

# Contents

- Outline dimensions ..... 5
- Transportation data ..... 8
- Performance data ..... 9
- Boom combinations ..... 10
- Main boom - Range diagram ..... 12
- Load chart - Main boom ..... 13
- Fixed jib - Range diagram ..... 14
- Load chart - Fixed jib ..... 15
- Luffing jib - Range diagram ..... 17
- Load chart - Luffing jib ..... 18
- Specifications ..... 20

# Outline dimensions

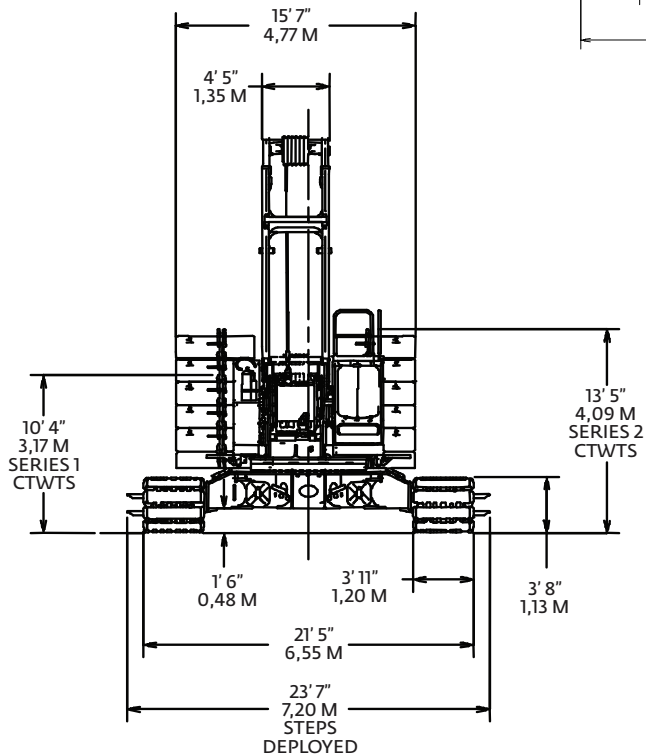
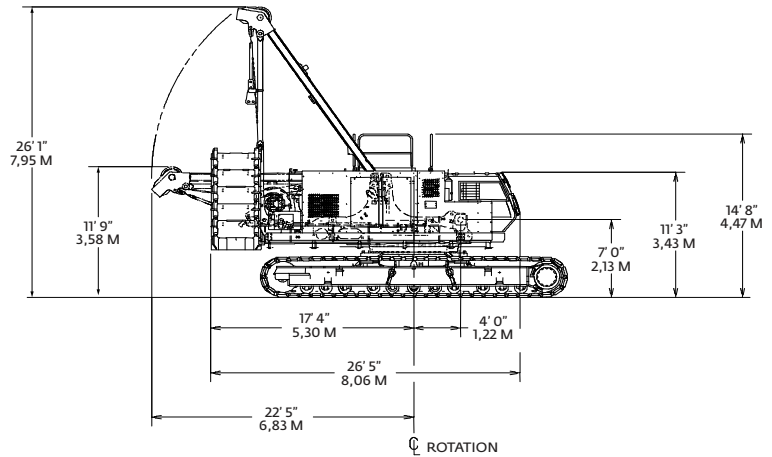
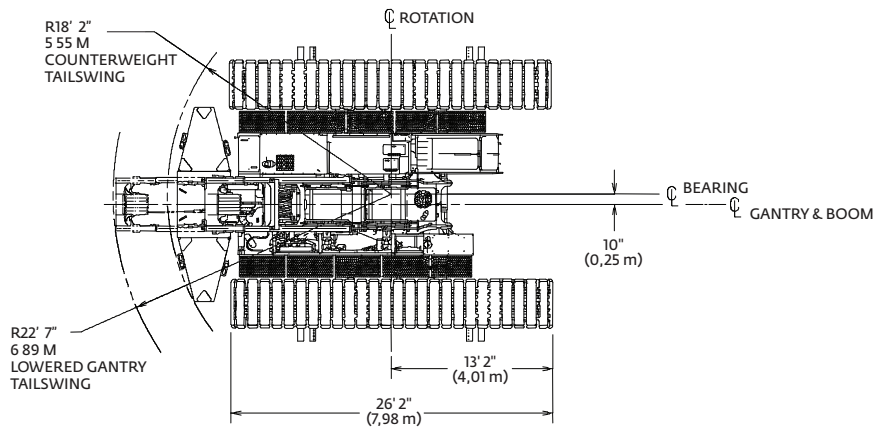

# Outline dimensions

Rotating Bed w/ Boom Butt	
Height	10' 5.5"
Length	49'
Width	9' 10"
Weight	88,700 lb

Note: includes third drum and wire rope

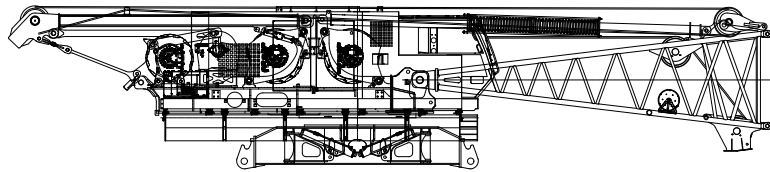

Crawler	
Height	3' 8"
Length	26' 2"
Width	4' 2"
Weight	36,300 lb

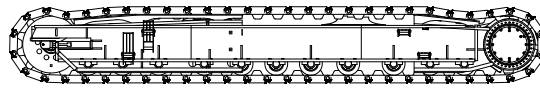

Counterweight Tray	
Height	4' 11"
Length	15' 9"
Width	4' 3"
Weight	22,000 lb

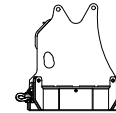
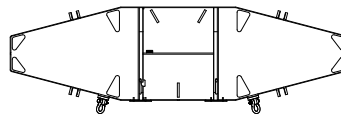

Upperworks Counterweight	
Height	1' 8"
Length	5' 1"
Width	4' 2"
Weight	8,800 lb

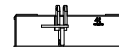
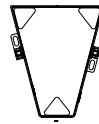

Carbody Counterweight	
Height	2' 10"
Length	7' 3"
Width	5' 11"
Weight	17,500 lb

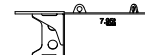
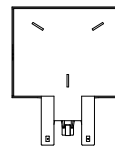

# Outline dimensions

Top	
Height	7' 4"
Length	26' 11"
Width	6' 6"
Weight	6,400 lb

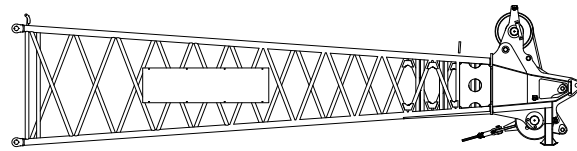

Upper Boom Point	
Height	2' 8"
Length	8' 8"
Width	1' 4"
Weight	1,200 lb

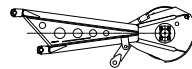

No. 134 basic fixed jib	
Height	4' 9"
Length	32' 6"
Width	7' 6"
Weight	29,00 lb

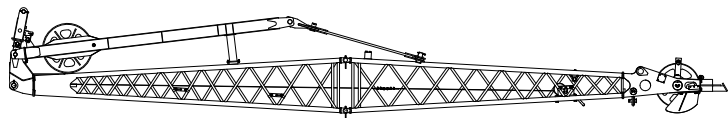

Boom and Jib Inserts				
	Height	Length	Width	Weight
<b>3m No. 350 boom insert</b>	2' 11"	10' 3"	2' 7"	320 lb
<b>6m No. 350 boom insert</b>	2' 11"	20' 3"	2' 7"	590 lb
<b>12m No. 350 boom insert</b>	4' 9"	32' 6"	7' 6"	2,900 lb
<b>3m No. 134 jib insert</b>	2' 11"	10' 3"	2' 7"	320 lb
<b>6m No. 134 jib insert</b>	2' 11"	20' 3"	2' 7"	590 lb

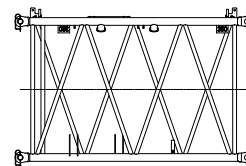

# Transportation Data

Load summary										
Item	255.9 ft B10:350 Boom and 80 ft FJ10:134 Fixed Jib									
	Qty	lb	1	2	3	4	5	6	7	8
Base Crane	1	88700	1							
CW Tray	1	22000				1				
Upper Box	10	8800						3	3	4
Lower Box	2	17500					2			
Boom top	1	6400				1				
Crawler	2	36300		1	1					
3m Boom Insert	1	1300			1					
6m Boom Insert	2	2100		1	1					
12m Boom Insert	4	3900					1	1	1	1
Upper Point	1	1200						1		
No. 134 Basic Jib	1	2600				1				
10' Jib Insert	1	300								1
20' Jib Insert	1	600		2						
Block	1	5500							1	
Weight Ball	1	1300							1	
Job Box	1	1000								1
Payload for each trailer (lb)			88,700	39,600	39,700	31,000	38,900	31,500	37,100	40,400

# Performance data

Front and Rear Drum Linespeed					
Single linepull (lb)	Single Line Speed				
	Layer				
	1	2	3	4	5
0	374	400	427	453	480
5,000	364	388	413	438	463
10,000	353	377	400	423	437
15,000	295	297	298	300	302
20,000	227	229	230	232	234
25,000	186	188	190	191	193
29,600	161	163	164	166	168

Third Drum Linespeed				
Single line pull lb	Single Line Speed			
	Layer			
	1	2	3	4
0	307	341	374	407
5,000	298	329	360	391
8,000	293	323	352	382
11,000	287	305	308	311
14,000	243	246	249	252
17,000	205	208	211	213
20,000	178	181	184	187

Front and Rear Drum Hoist Reeving	
Parts of line	Max load (lb)
1	29,600
2	59,200
3	88,800
4	118,400
5	148,000
6	177,600
7	207,200
8	236,800
9	266,400
10	296,000
11	325,600
12	330,600

Third Drum Hoist Reeving	
Parts of line	Max Load (lb)
1	20,000
2	40,000

# Boom combinations

B10:350 boom combinations			
Boom length ft	Boom inserts length ft		
	9.8	19.7	39.4
49.2	0	0	0
59.1	1	0	0
68.9	0	1	0
78.7	1	1	0
88.6	0	0	1
98.4	1	0	1
108.3	0	1	1
118.1	1	1	1
128	0	0	2
137.8	1	0	2
147.6	0	1	2
157.5	1	1	2
167.3	0	0	3
177.2	1	0	3
187	0	1	3
196.9	1	1	3
206.7	0	0	4
216.5	1	0	4
226.4	0	1	4
236.2	1	1	4
246.1	0	2	4
255.9	1	2	4

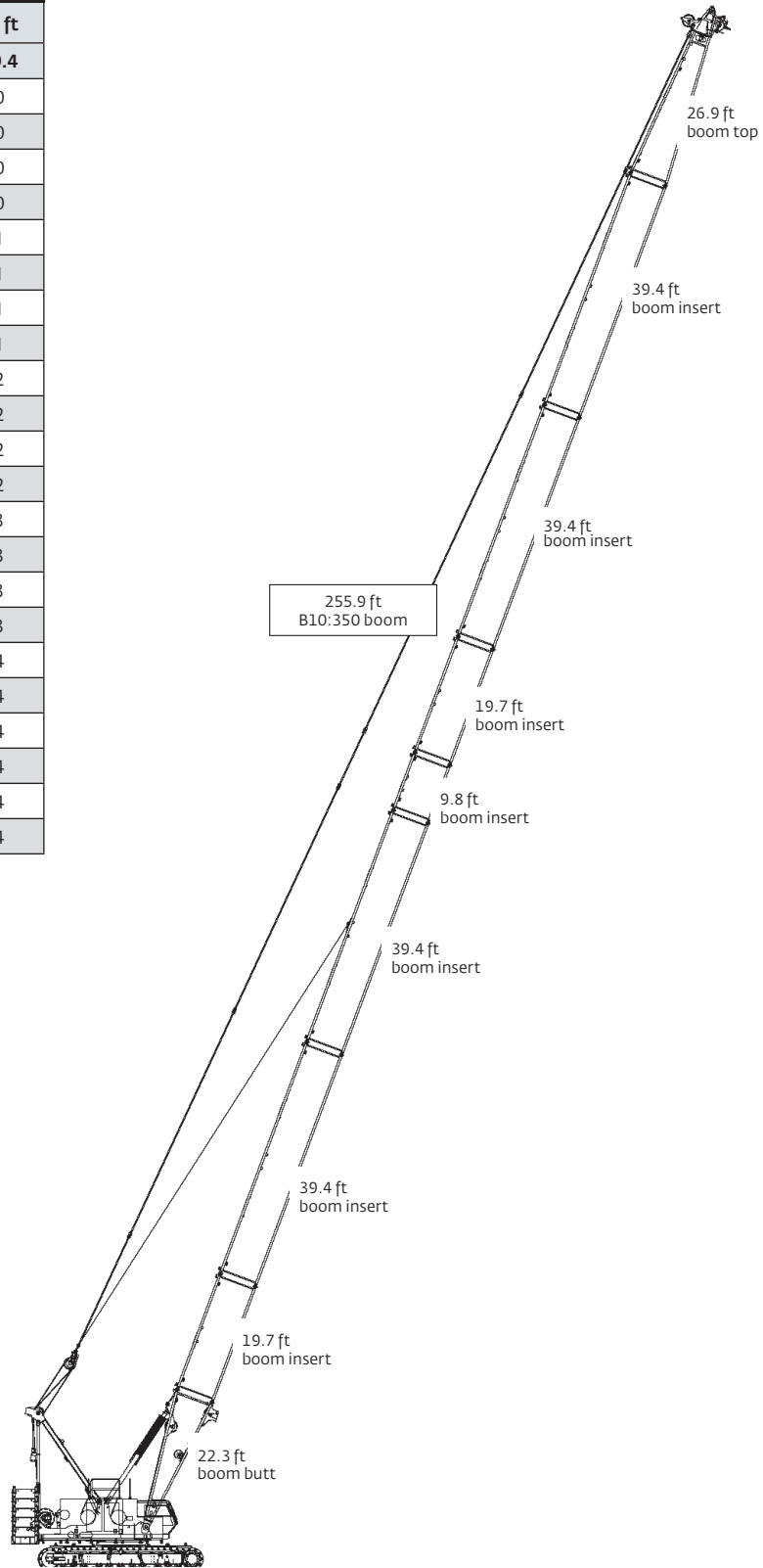

# Boom combinations

No. 134 fixed jib combinations		
Jib length ft	Jib inserts length ft	
	10	20
30	0	0
40	1	0
50	0	1
60	1	1
70	0	2
80	1	2

No. 135A luffing jib combinations			
Jib length ft	Jib inserts length ft		
	10	20	40
70	0	1	0
80	1	1	0
90	0	0	1
100	1	0	1
110	0	1	1
120	1	1	1
130	0	0	2
140	1	0	2
150	0	1	2
160	1	1	2
170	0	0	3

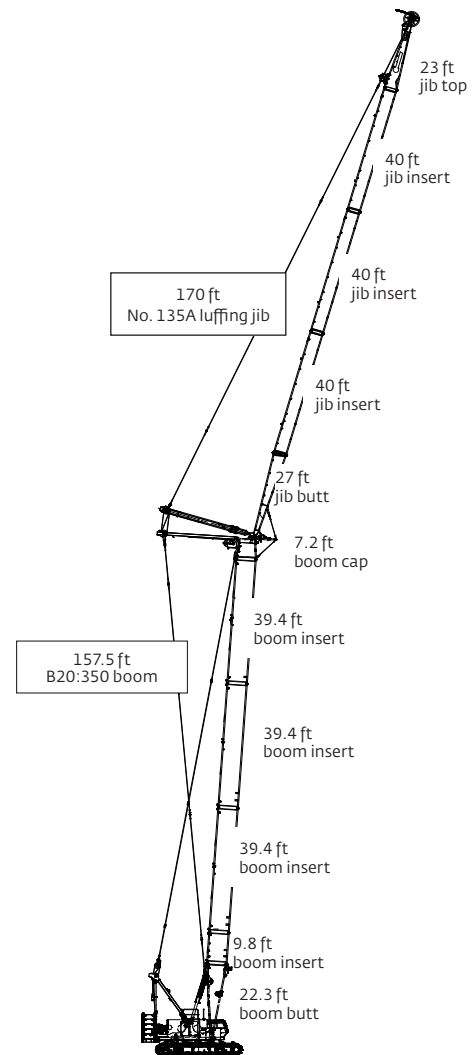
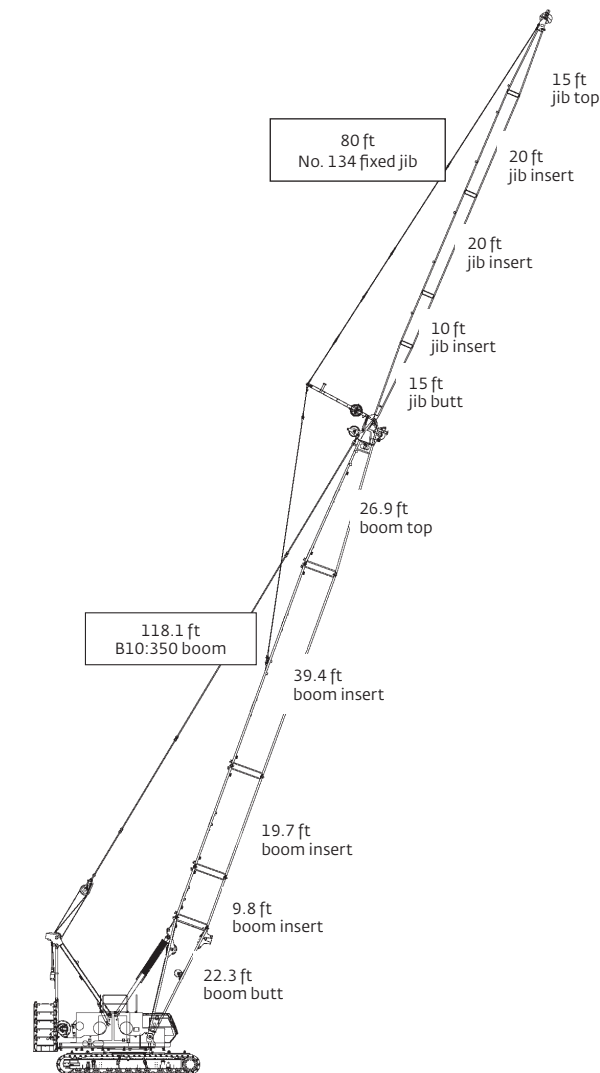

# Main boom range diagram

B10:350 boom

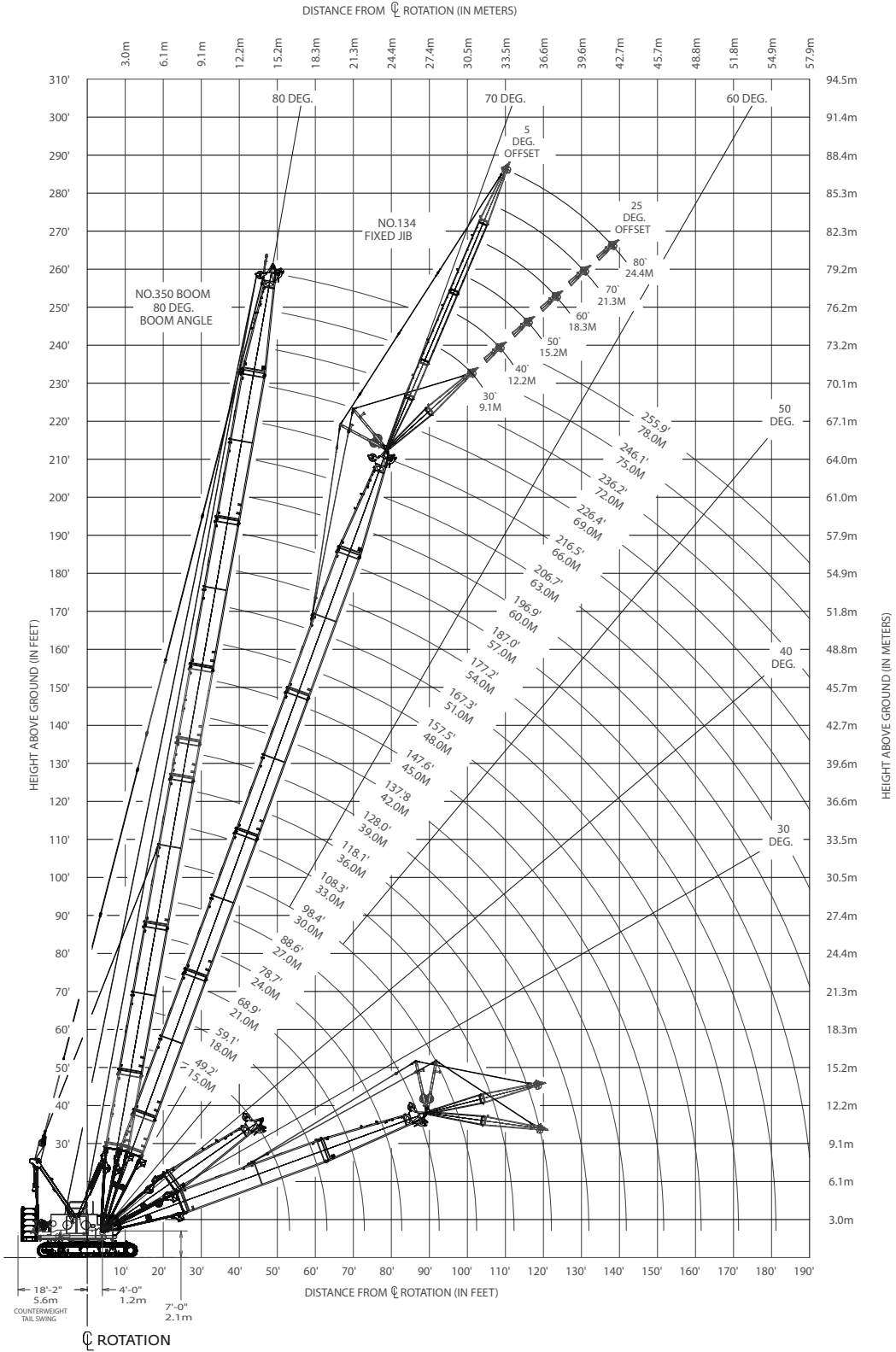

# Main boom load chart

**B10:350 boom**

**110,500 lb upper counterweight, 35,000 lb carbody counterweight**

360° Radius (ft)	lb x 1000										
	Boom length (ft)										
	49	69	89	108	128	148	167	187	207	226	246
14	330.6										
15	313.4										
17	276.5										
19	247.4	247.4									
22	213.7	213.7	213.7								
26	180.8	180.8	180.8	180.8							
30	155.1	156.1	156.0	155.8	155.5						
34	128.9	129.8	129.7	129.4	129.0	128.6	124.4				
38	109.9	110.8	110.6	110.3	109.9	109.5	109.0	104.3			
42	95.6	96.5	96.2	95.9	95.4	95.0	94.5	94.0	84.5		
46	84.3	85.2	84.9	84.6	84.1	83.6	83.1	82.6	82.0	70.3	
50		76.1	75.8	75.5	75.0	74.5	73.9	73.4	72.8	69.0	55.8
55		67.0	66.7	66.4	65.8	65.3	64.7	64.2	63.6	63.0	54.5
60		59.7	59.4	59.0	58.5	58.0	57.4	56.8	56.2	55.6	53.3
65		53.6	53.3	53.0	52.4	51.9	51.3	50.7	50.1	49.5	48.8
70			48.3	47.9	47.4	46.9	46.2	45.6	45.0	44.4	43.7
75			44.0	43.6	43.1	42.6	41.9	41.3	40.7	40.0	39.3
80			40.3	40.0	39.4	38.9	38.2	37.6	37.0	36.3	35.6
85			37.1	36.8	36.2	35.7	35.0	34.4	33.7	33.1	32.4
90				34.0	33.4	32.9	32.2	31.6	30.9	30.3	29.5
95				31.5	30.9	30.4	29.7	29.1	28.4	27.8	27.0
100				29.2	28.7	28.2	27.5	26.9	26.2	25.5	24.8
105					26.7	26.2	25.5	24.9	24.2	23.5	22.8
110					24.9	24.4	23.7	23.1	22.4	21.7	21.0
115					23.3	22.8	22.1	21.5	20.8	20.1	19.4
120					21.8	21.3	20.6	20.0	19.3	18.6	17.9
125						19.9	19.3	18.7	18.0	17.3	16.5
130						18.7	18.0	17.4	16.7	16.0	15.3
135						17.5	16.9	16.3	15.6	14.9	14.1
140							15.8	15.2	14.5	13.8	13.1
145							14.8	14.2	13.5	12.8	12.1
150							13.9	13.3	12.6	11.9	11.2
160								11.7	11.0	10.3	9.5
170								10.2	9.5	8.8	8.1
180									8.2	7.5	6.8
190									7.1	6.4	5.6
200										5.4	4.6
210											3.5

For complete chart, refer to [www.cranelibrary.com](http://www.cranelibrary.com).

THIS CHART IS ONLY A GUIDE AND SHOULD NOT BE USED TO OPERATE THE CRANE.  
The individual crane's load chart, operating instructions and other instructional plates must be read and understood prior to operating the crane

# Fixed jib range diagram

B10:350 boom

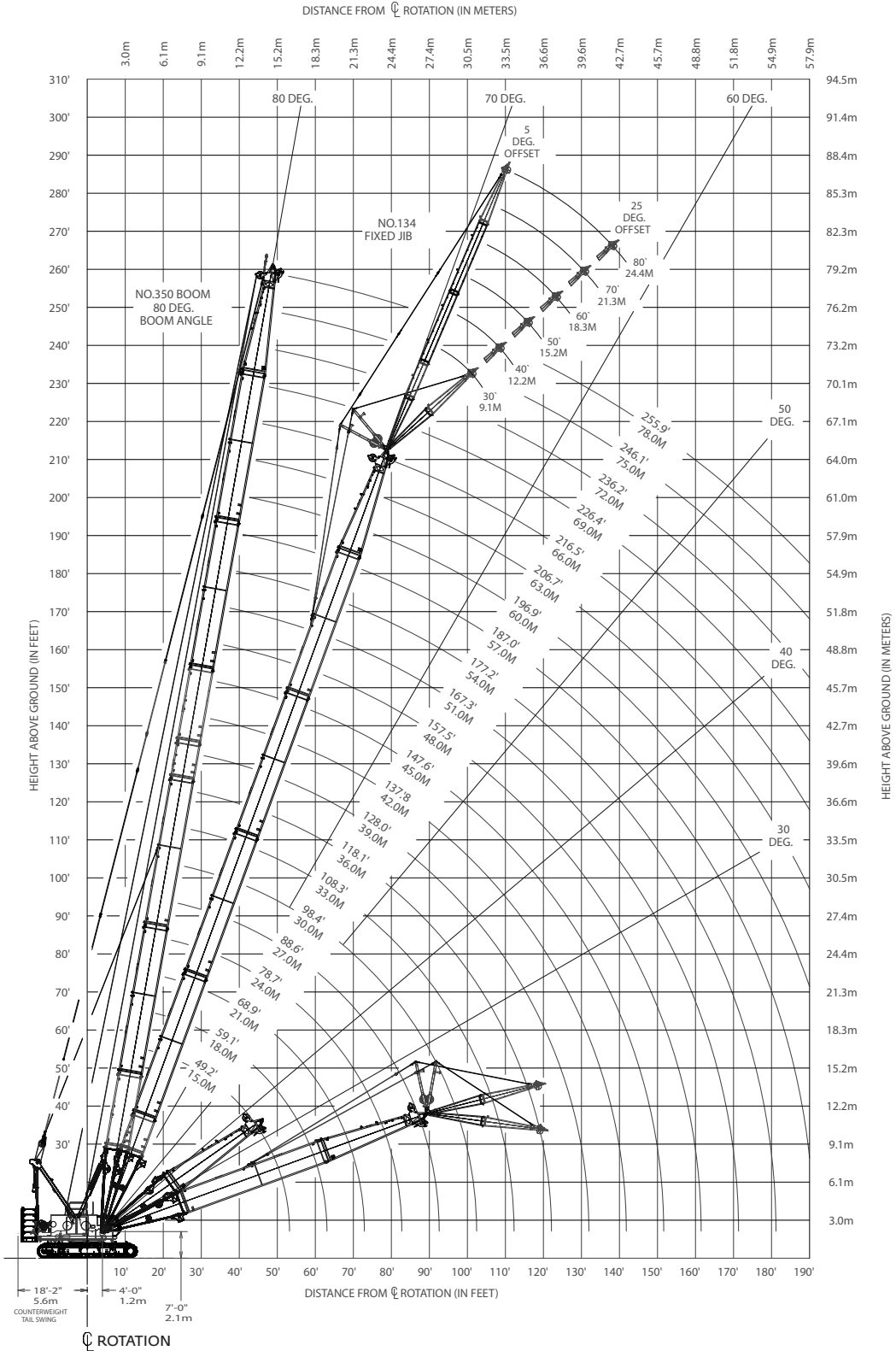

# Fixed jib load chart

No. 134 fixed jib on B10:350 boom series 2

110,500 lb upper counterweight, 35,000 lb carbody counterweight

360°

lb x 1000

## 30 ft jib at 5° offset

Radius (ft)	Boom Length (ft)				
	89	118	148	177	207
34	59.2				
36	59.2	59.2			
40	59.2	59.2			
44	59.2	59.2	59.2		
48	59.1	59.2	59.2	58.3	
50	58.5	59.2	59.2	58	
55	57.4	58.6	58.6	57.4	48.5
60	56.2	57.5	57.7	56.7	48.1
65	53.8	52.8	51.9	50.8	47.7
70	48.7	47.7	46.8	45.7	44.7
75	44.4	43.4	42.4	41.4	40.4
80	40.7	39.7	38.7	37.6	36.6
85	37.5	36.5	35.5	34.4	33.4
90	34.7	33.7	32.7	31.6	30.5
95	32.2	31.2	30.2	29	28
100	30	28.9	27.9	26.8	25.8
110	26.2	25.1	24.1	23	22
120		22	21	19.9	18.8
130		19.4	18.4	17.3	16.2
140		17.2	16.2	15.1	14
150			14.3	13.2	12.1
160			12.6	11.5	10.4
170				10	9
180				8.8	7.7
190				7.6	6.6
200					5.5
210					4.4
220					3.4

## 40 ft jib at 5° offset

Radius (ft)	Boom Length (ft)				
	89	118	148	177	207
34	52.4				
36	51.8				
40	50.7	51.3			
44	49.8	50.4			
48	48.8	49.6	49.5		
50	48.4	49.3	49.2		
55	47.3	48.4	48.5	47.6	
60	46.3	47.5	47.8	47	42.4
65	45.4	46.7	47.1	46.5	42.2
70	44.6	46	46.5	46	41.9
75	43.7	43.8	42.8	41.8	40.8
80	41.1	40.1	39.1	38	37.1
85	37.9	36.9	35.9	34.8	33.8
90	35.1	34	33	31.9	30.9
95	32.6	31.5	30.5	29.4	28.4
100	30.3	29.3	28.3	27.2	26.1
110	26.5	25.5	24.5	23.3	22.3
120	23.4	22.3	21.3	20.2	19.1
130		19.7	18.7	17.6	16.5
140		17.5	16.5	15.3	14.3
150		15.6	14.6	13.4	12.4
160			12.9	11.8	10.7
170			11.4	10.3	9.2
180				9	7.9
190				7.8	6.8
200				6.8	5.7
210					4.7
220					3.7

THIS CHART IS ONLY A GUIDE AND SHOULD NOT BE USED TO OPERATE THE CRANE.

The individual crane's load chart, operating instructions and other instructional plates must be read and understood prior to operating the crane

# Fixed jib load chart

No. 134 fixed jib on B10:350 boom series 2

110,500 lb upper counterweight, 35,000 lb carbody counterweight

360°

lb x 1000

50 ft jib at 5° offset					
Radius (ft)	Boom Length (ft)				
	89	118	148	177	207
40	42.7				
42	42.2	42.6			
44	41.8	42.2			
50	40.6	41.2	41.1		
55	39.6	40.4	40.5	39.8	
60	38.7	39.6	39.9	39.3	36.9
65	37.9	38.9	39.2	38.8	36.7
70	37	38.3	38.6	38.3	36.5
75	36.2	37.6	38.1	37.8	36.3
80	35.5	36.9	37.6	37.4	36.2
85	34.7	36.3	36.1	35.1	34.1
90	33.9	34.3	33.3	32.2	31.2
95	32.2	31.8	30.7	29.7	28.6
100	30.6	29.5	28.5	27.4	26.4
110	26.8	25.7	24.7	23.6	22.5
120	23.6	22.6	21.5	20.4	19.4
130	21	20	18.9	17.8	16.7
140		17.7	16.7	15.5	14.5
150		15.8	14.8	13.6	12.6
160		14.1	13.1	12	10.9
170			11.6	10.5	9.4
180			10.3	9.2	8.1
190				8	7
200				7	5.9
210				6	4.9
220					3.9

60 ft jib at 5° offset					
Radius (ft)	Boom Length (ft)				
	89	118	148	177	207
40	36.6				
42	36.3				
46	35.5	35.8			
48	35.2	35.5			
50	34.7	35.3	35.1		
55	33.7	34.5	34.5		
60	32.7	33.8	34	33.5	
65	31.9	33	33.4	33	31.4
70	31	32.2	32.8	32.9	31.3
75	30.2	31.5	32.2	32.2	31.1
80	29.5	30.9	31.6	31.7	31
85	28.7	30.2	31	31.3	30.7
90	28.1	29.5	30.4	30.8	30.4
95	27.5	29	29.9	29.8	28.8
100	26.8	28.4	28.6	27.5	26.5
110	24.3	25.9	24.8	23.7	22.7
120	22.3	22.7	21.7	20.5	19.5
130	20.6	20.1	19.1	17.9	16.8
140	19	17.9	16.8	15.7	14.6
150		16	14.9	13.8	12.7
160		14.3	13.2	12.1	11
170			11.8	10.6	9.5
180			10.5	9.3	8.2
190			9.3	8.2	7.1
200				7.1	6
210				6.2	5
220				5.3	4
230					3.1

*THIS CHART IS ONLY A GUIDE AND SHOULD NOT BE USED TO OPERATE THE CRANE.  
The individual crane's load chart, operating instructions and other instructional plates must be read and understood prior to operating the crane*



# Luffing jib load chart

No. 135A luffing jib on B20:350 series 2

110,500 lb upper counterweight, 35,000 lb carbody counterweight

360°

lb x 1000

## 70 ft luffing jib length

Radius (ft)	Boom Length (ft)				
	68.9	98.4	128.0	157.5	207
30	108.8	96.7			
32	104.9	96.6			
34	100.4	96.6			
36	96.3	93.4	84.5		
38	92.4	88.9	84.5	70.3	
40	88.8	84.7	84.3	69.0	36.9
42	85.4	81.0	81.4	67.6	36.7
44	82.2	77.6	78.0	66.1	36.5
46	78.7	74.5	74.8	64.6	36.3
48	75.5	71.7	72.0	63.1	36.2
50	72.6	69.1	69.3	61.5	34.1
55	63.0	63.4	63.6	57.7	31.2
60	55.3	58.8	58.9	53.9	28.6
65	49.1	54.9	55.1	50.3	26.4
70	43.8	51.7	51.8	47.0	22.5
75	39.3	49.1	48.6	44.0	19.4
80		45.5	44.7	41.3	16.7
85			41.2	40.0	14.5

## 100 ft luffing jib length

Radius (ft)	Boom Length (ft)				
	68.9	98.4	128.0	157.5	207
38	80.1	73.5			
40	78.6	73.4			
42	77.1	73.2			
44	75.3	73.0	65.6		
46	73.0	72.6	65.1	49.1	
48	70.6	70.8	64.1	48.7	
50	68.4	68.0	62.9	48.3	
55	63.5	62.1	59.9	46.8	31.4
60	58.3	57.3	56.8	44.7	31.3
65	51.6	53.2	52.9	42.5	31.1
70	46.3	49.7	49.4	40.2	31
75	41.8	46.7	46.5	38.0	30.7
80	38.0	44.1	43.9	35.9	30.4
85	34.8	41.8	40.9	33.9	28.8
90	31.9	38.9	38.0	32.0	26.5
95	29.4	36.3	35.5	30.2	22.7
100	27.2	34.0	33.2	28.6	19.5
105	25.1	31.9	31.2	27.1	16.8
110		29.9	29.3	25.7	14.6
115			27.5	24.6	12.7

*THIS CHART IS ONLY A GUIDE AND SHOULD NOT BE USED TO OPERATE THE CRANE.*

*The individual crane's load chart, operating instructions and other instructional plates must be read and understood prior to operating the crane*

# Luffing jib load chart

No. 135A luffing jib on B20:350 series 2

110,500 lb upper counterweight, 35,000 lb carbody counterweight

360°

lb x 1000

## 140 ft luffing jib length

Radius (ft)	Boom Length (ft)				
	68.9	98.4	128.0	157.5	207
48	46.8	44.4			
50	46.5	44.0			
55	45.6	43.3	41.0		
60	44.7	42.6	40.3	33.4	
65	43.5	41.8	39.1	32.4	
70	41.8	41.1	37.9	31.4	
75	40.1	39.7	36.6	30.3	48.5
80	38.4	38.3	35.2	29.2	48.1
85	36.9	36.8	33.8	28.1	47.7
90	33.9	35.4	32.4	26.9	44.7
95	31.2	34.0	30.9	25.7	40.4
100	28.8	32.6	29.6	24.6	36.6
105	26.7	31.2	28.2	23.6	33.4
110	24.9	29.4	26.9	22.5	30.5
115	23.3	27.7	25.6	21.5	28
120	21.7	26.2	24.4	20.5	25.8
125	20.3	24.8	23.2	19.6	22
130	19.1	23.5	22.1	18.7	18.8
135	17.9	22.3	21.1	17.9	16.2
140	16.8	21.2	20.1	17.1	14
145	15.7	20.1	19.3	16.4	12.1
150		19.1	18.5	15.9	10.4
155			17.7	15.4	9

## 170 ft luffing jib length

Radius (ft)	Boom Length (ft)				
	68.9	98.4	128.0	157.5	207
55	35.2				
60	34.6	32.1			
65	33.9	31.6	28.0		
70	32.5	31.0	27.7	24.6	
75	31.0	30.8	27.3	24.2	
80	29.5	29.5	26.9	23.6	
85	28.2	28.2	26.0	23.0	
90	26.8	26.9	24.9	22.4	42.4
95	25.5	25.6	23.8	21.7	42.2
100	24.3	24.5	22.8	21.0	41.9
105	23.1	23.3	21.8	20.3	40.8
110	21.9	22.2	20.8	19.6	37.1
115	20.8	21.1	19.9	19.0	33.8
120	19.8	20.1	18.9	18.3	30.9
125	18.8	19.1	18.1	17.6	28.4
130	17.8	18.1	17.2	16.9	26.1
135	16.9	17.2	16.3	16.4	22.3
140	16.0	16.3	15.6	15.7	19.1
145	15.2	15.5	14.8	15.1	16.5
150	14.3	14.6	14.0	14.4	14.3
155	13.6	13.9	13.3	13.7	12.4
160	12.6	12.9	12.4	12.8	10.7
165	11.7	12.0	11.6	12.0	9.2
170	10.9	11.2	10.8	11.2	7.9
175	10.1	10.4	10.0	10.4	6.8
180		9.7	9.4	9.8	5.7
185			8.8	9.1	4.7

*THIS CHART IS ONLY A GUIDE AND SHOULD NOT BE USED TO OPERATE THE CRANE.*

*The individual crane's load chart, operating instructions and other instructional plates must be read and understood prior to operating the crane*

# Specifications

## Upperworks

### Engine

Cummins Model QSB6.7 Tier 4 Final (Stage V), 6 cylinder diesel, 325 hp (240 kW) at 2200 governed RPM. High sulfur fuel compatible Euro Stage 2 compliant version available.

Includes exhaust aftertreatment system (Tier 4 Final / Stage V) or muffler, air cleaner, 70 amp alternator, radiator and fan. Also includes 125 gallon (473 liter) capacity diesel fuel tank, and a 15 gallon (57 liter) capacity diesel exhaust fluid (DEF) tank.

### Crane Control System

The Crane Control System (CCS) offers a user-friendly interface, full graphic display mounted vertically for better visibility, a jog dial for easier data input and ergonomic joysticks. Block-up limit control is standard for hoist and whip lines. Travel and swing alarms are standard. RCL/RCI (Rated Capacity Limiter/Rated Capacity Indicator) system is standard.

### Hydraulic system

Three high-pressure pumps are driven by the engine. Two pumps provide “open loop” hydraulic power enabling simultaneous multi-function capability. One pump provides independent “closed loop” hydraulic power for the swing system. An additional pump provides hydraulic power for the cooler fan and an additional pump is included with free fall. Hydraulic reservoir capacity is 115 gallon (436 liter) and is equipped with breather, sight and electrical level indicator, clean out access, and internal diffuser. Replaceable, full flow tank filters are furnished in the hydraulic circuit. All oil is filtered prior to return to the hydraulic reservoir. Hydraulic system also includes hydraulic oil cooler.

### Drums

Two 29.5 inch (750 mm) width drums are driven by independent variable displacement axial piston hydraulic motors through planetary reduction. Drums are grooved for 26 mm rope and mounted in rotating bed. Powered hoisting/lowering operation is standard with automatic (spring applied, hydraulically released) multi-disc brakes, and drum rotation indicators.

- Optional: free-fall operation for front and/or rear drums.
- Optional: auxiliary (third) hydraulic powered drum mounted in rotating bed. Drum is grooved for 26 mm rope. All hydraulic and electrical components to equip drum come along with the drum.

### Boom hoist

Independent boom hoist consists of a single drum grooved for 0.875 inch diameter wire rope. Includes 0.875 inch diameter wire rope for boom hoist reeving. Drum is powered by a fixed displacement hydraulic motor coupled to an internal brake and planetary gearbox equipped with ratchet and pawl.

### Gantry

The 10 part boom hoist reeving is reeved between the 6 sheave gantry and 5 sheave equalizer, with the dead end on the rotating bed. When used with optional self-erect sheave in the boom butt the machine is capable of installing carbody counterweights, stacking the upperworks counterweights and assembling the boom and jib. The gantry is also utilized to lift the entire upperworks counterweight assembly into place, controlled by remote control.

### Counterweight

The upperworks counterweight is attached to rotating bed with remote controlled hydraulically actuated pins. The upperworks counterweight consists of a one-piece tray and four upper counterweight boxes. Carbody counterweight boxes are each attached to carbody.

*Series 1* - Upper counterweight (6 pieces+tray)

75,300 lb (34,155 kg)

*Series 2* - Upper counterweight (10 pieces+tray)

110,500 lb (50,120 kg)

Carbody counterweight (2 pieces)

35,000 lb (15,880 kg)

Total counterweight 145,500 lb (66,000 kg)

### Swing system

Independent single swing drive mounted in rotating bed is powered by a hydraulic motor driving a spur gear through a planetary reduction with internal brake.

Maximum swing speed: 2.0 rpm.

- Optional: electronic swing position indicator and swing limiter

### Operator's cab

New wider cab provides 10% increased operator legroom. Fully enclosed and galvaneled steel insulated module is equipped with sliding door, large safety glass windows on all sides and roof. Signal horn, cab space heater, front and roof windshield wipers, air conditioning, dome light, sun visor and shade, fire extinguisher and air circulating fan are standard.

- Optional: External RCI light, electronic level indicator, radio and camera system

# Specifications

## Lowerworks



### Carbody

High strength fabricated steel assembly utilizing Manitowoc's FACT™ connection system incorporating two hydraulically powered pins for fast installation and removal of crawlers.



### Crawlers

Crawler assemblies are 26' 3" (8 m) long, high strength steel fabrications with 3' 11" (1.2 m) wide cast steel crawler pads. Each crawler is powered independently by a variable displacement hydraulic motor driving a planetary reduction. Maximum ground speed of 1.3 mph. (2.1 km/hr).

## Attachments



### No. 350 boom

The liftcrane is equipped with a 49' 2" (15 m) basic No. 350 tubular chord boom consisting of a 22' 4" (6.8 m) butt and 26' 10" (8.2 m) top with five 25.6" diameter roller bearing sheaves. No. 350 boom utilizes steel boom suspension straps. Boom butt has incorporated equalizer rails for connecting to equalizer to boom butt, boom butt also remains installed for transportation.

Spring cushioned boom stop and electronic automatic boom stop standard.

- Optional: No. 350 boom lengths are increased using 9' 10" (3 m), 19' 8" (6 m), and 39' 4" (12 m) boom inserts with steel boom suspension straps. Max boom length is 255' 10".



### No. 134 fixed jib

30' (9.1 m) basic No. 134 tubular chord fixed jib consisting of 15' (4.6 m) jib butt and 15' (4.6 m) jib top with 12' (3.7 m) jib strut, and wire rope, pendants. Includes RCL/RCI hardware.

- Optional: No. 134 fixed jib lengths are increased using 10' (3 m) inserts with wire rope pendants. Max fixed jib length is 60' (18.3 m).



### No. 135 luffing jib

70' (21.3 m) basic No. 135 tubular chord luffing jib assembly with RCI hardware consisting of 27' (8.2 m) butt, 20' (6.1 m) insert and 23' (7 m) top with two 27" (68.6 cm) straight roller bearing sheave, pin connected jib sections, pendants, main strut, jib strut, backstay pendants, boom point wheel for use with No. 350 boom. Also includes 6' 7" (2 m) No. 350 boom cap.

- Optional: No.135 luffing jib lengths are increase using 10' (3 m), 20' (6.1 m) and 40' (12.2 m) No. 135 inserts with pendants. Max luffing jib length is 170' (51.8 m).

## Optional equipment

- Detachable upper boom point with one 30 in diameter tapered roller bearing sheave for No. 350 boom top
- Blocks and hooks:
  - 16.5 USt (15 mT) cylindrical weight ball with swivel hook.
  - 33.1 USt (30 mT) hook block with one 24 in sheaves for 26 mm wire rope with swivel hook and hook latch.
  - 93.7 USt (85 mT) hook block with three 24 in sheaves for 26 mm wire rope with swivel hook and hook latch.
  - 148.8 USt (135 mT) hook block with five 24 in sheaves for 26 mm wire rope with swivel hook and hook latch.
- Hydraulic test kit: recommended to properly analyze the performance of the hydraulic system
- Service interval kits: including the items necessary to perform general scheduled maintenance, available through Crane Care
- Special paint color: other than Manitowoc standard red and black
- Special customer decals: custom vinyl decal(s) of name and/or logo from artwork supplied by customer
- Export packaging: basic crane, boom and jib sections
- Cold weather package of heaters for engine coolant, engine oil, hydraulic tank and batteries
- Rotating bed and boom lights
- Generator 5.0 kW to run cold weather package or rotating bed and boom lights

# Notes

# Notes

# The Manitowoc Company, Inc.

## Regional headquarters

### Americas

Milwaukee, Wisconsin, USA  
Tel: +1 414 760 4600

Shady Grove, Pennsylvania, USA  
Tel: +1 717 597 8121

### Europe and Africa

Dardilly, France - TOWERS  
Tel: +33 (0) 4 72 18 20 20

Wilhelmshaven, Germany - MOBILE  
Tel: +49 (0) 4421 294 0

### APAC

Shanghai, China  
Tel: +86 21 6457 0066

Singapore  
Tel: +65 6264 1188

### Middle East and India

Dubai, UAE  
Tel: +971 4 8862677

This document is non-contractual. Constant improvement and engineering progress make it necessary that we reserve the right to make specification, equipment, and price changes without notice. Illustrations shown may include optional equipment and accessories and may not include all standard equipment.

